

OMD

series

Mini Dumper



ORAKCI
Makina İmalat İth. İhr. San. ve Tic. A.Ş.



1. Equipment Dimensions

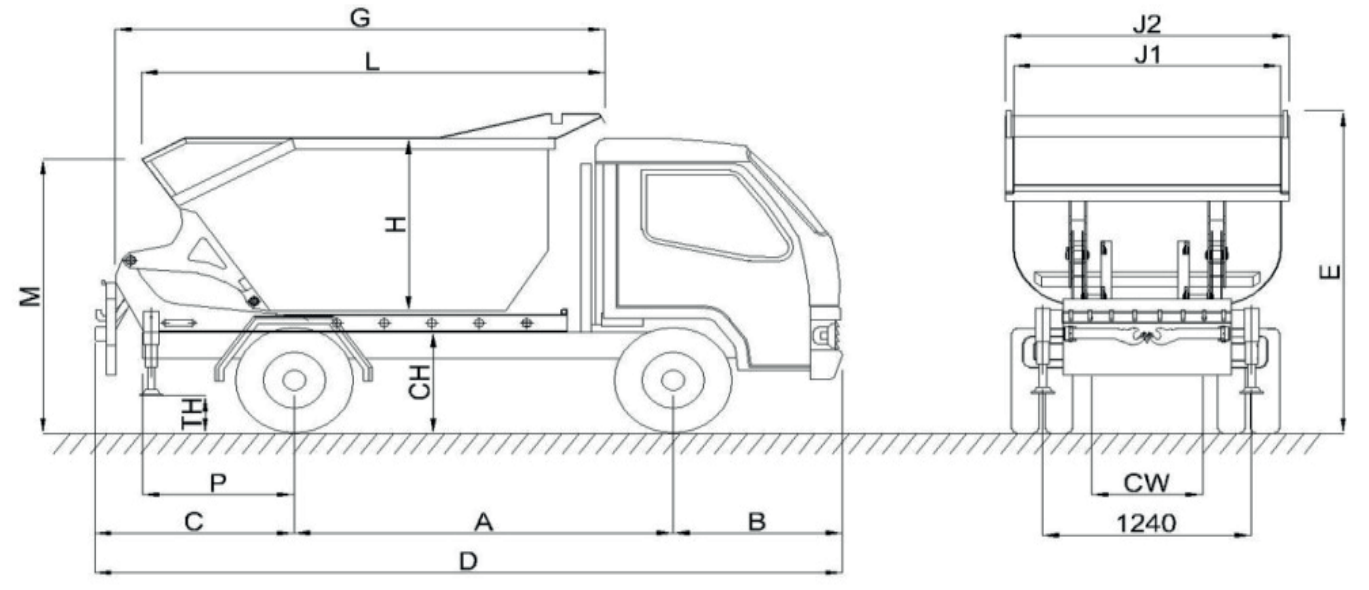

Equipment capacity can be made between 1,5m³ and 5m³. For the equipments lesser than 3,5m³, please contact ORAKÇI MAKİNA.

Equipment Dimensions List

	Letter Code	3,5m³	5m³
Rear Overhang	*C»	May differ by truck.	
Truck Ground Clearance	*CH	671	713
Truck Total Length	D	4395	5329
Body Height	*E	2120	2231
Body Internal Height	H	1145	1145
Truck Chassis Width	CW	May differ by truck.	
Body Length	G	2910	3697
Hopper Height	M	1820	1859
Body Internal Width	J1	1585	1585
Body External Width	J2	1690	1690
Chassis Back Length	*P	May differ by truck.	

- The dimensions are given in mm.
- Parts marked with (*) may differ by truck. The final dimensions become clear after the draft work. The table is for information purposes.
- The information given is the base equipment data, it does not include equipment or accessories.
- The equipment dimensions may vary by ±3% depending on the general tolerances.

2. Container Capacity

Capacity	OMD
	3,5 m³ - 5 m³



3. Hydraulic Features

Powerpack	OMD 01
	12/24 V



4. Materials Used

Powerpack	Body Bottom	Body Side Wall	Body Back Sheet
	S355J2C+N	S355J2C+N	S355J2C+N
	Hardox 450 (Optional)		Hardox 450 (Optional)



5. Optional Features

Hydraulic Control System	Manual Semi-automatic Automatic	Hardox	HARDOX® WEAR PLATE
Electrical Control System	PLC ECU ECU-CANBUS	Equipment Control Directions	Right / Left
EN 1501 - Refuse collection vehicles - General requirements and safety requirements		Inner Cabin Control	
Camera		Remote Control	
Bin Lifter		Bicycle Stand EN 1501	
Mud Guards		Recorder	
Fire Extinguisher Box			

Please contact ORAKCI MAKİNA for optional requests.



6. Truck Warning Alarm System

Equipment Dimensions List		
Manual	Semi-automatic	Automatic
Beacon Light	Beacon Light	Beacon Light
Stop Lamps	Stop Lamps	Stop Lamps
Driver Warning (Optional)	Driver Warning (Optional)	Driver Warning
Side Marker Light (Optional)	Side Marker Light (Optional)	Side Marker Light (Optional)
Side Beacon Light (Optional)	Side Beacon Light (Optional)	Side Beacon Light (Optional)
		Reversing Buzzer
		Camera System (Optional)



8) Following the analysis of each designed equipment via the programs, mass production of them is carried out after testing for at least 6 months in the field test.

9) The equipment is designed for use in narrow streets.

11) 1-year product warranty and 10-year spare parts supply warranty is provided.

12) Through the installation of a closed-circuit camera system in the driver's cabin, the communication of the driver with the operators is increased and work safety is ensured. Ease of use is offered via an optional touch screen.

10) Feature of functioning as a transfer vehicle by transferring to the hydraulic compressed refuse equipment. Makes it easy to keep up the collection process without the need to go to the landfill.

13) Since the equipment is monoblock (single piece), there is no waste water leakage problem.

14) During the damper lifting operation of the equipment, stabilizers are used in line with the work safety procedures.

