

OKG

series

TELESCOBIC VEHICLE
RECOVERY

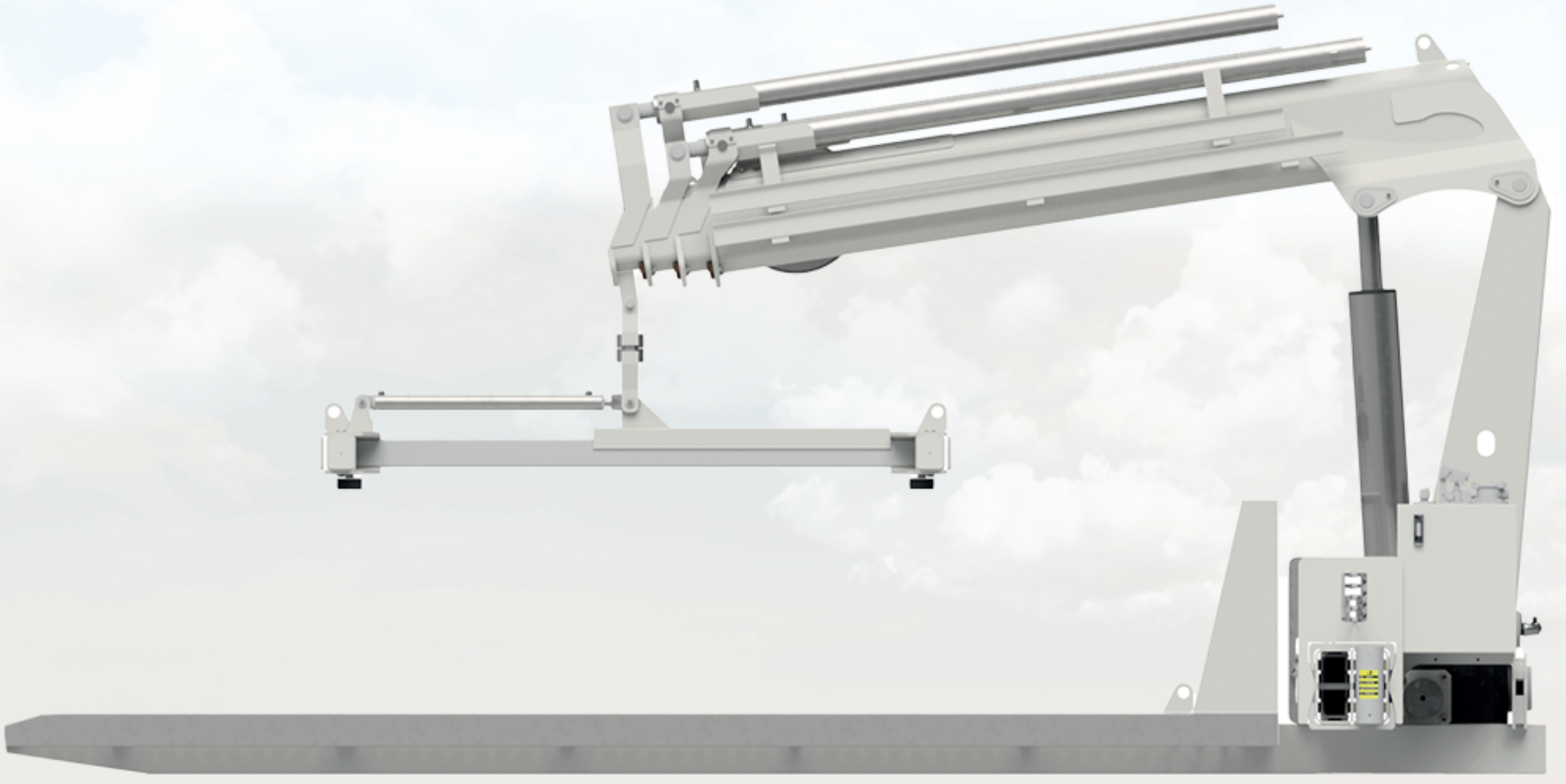

ORAKCI
Makina İmalat İth. İhr. San. ve Tic. A.Ş.



1. Equipment Dimensions

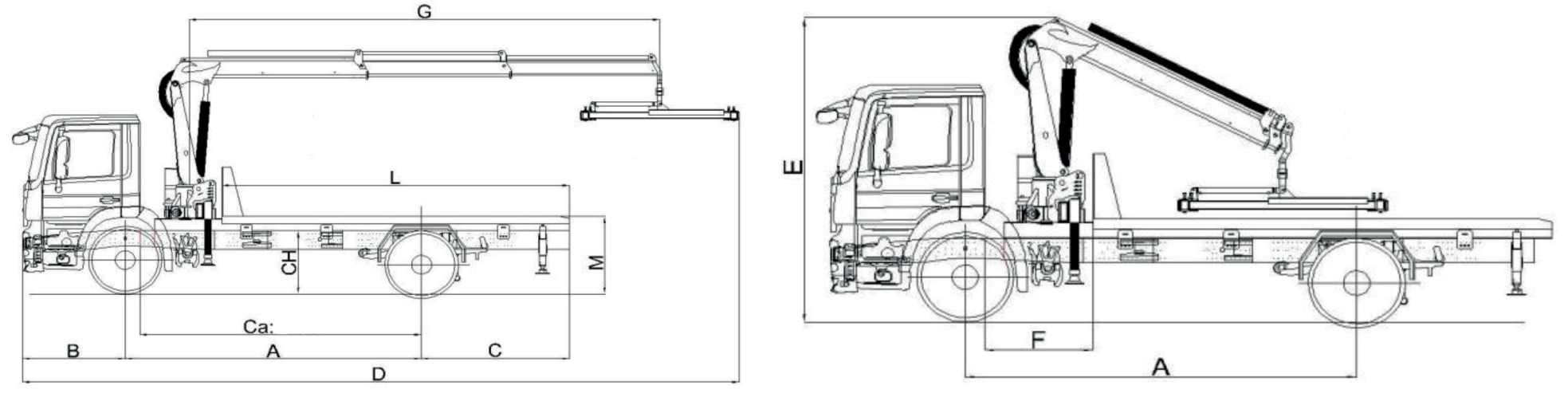

Equipment Dimensions List

Letter Code	OKG 11(2-3 BOM)	OKG 15(3-4 BOM)	OKG 20(3-4 BOM)
*A	4160 mm	4000 mm	4200 mm
*B	-	-	-
*C	-	-	-
*Ca	-	-	-
*CH	-	-	-
*D	-	-	-
*E	-	-	-
*F	1050 mm	1050 mm	1050 mm
*G	6600 mm(3 BOM)	8910 mm(3 BOM) 10400(4 BOM)	8500(3 BOM) 10400(4 BOM)
L	4750 mm	4750 mm	4750 mm
*M	-	-	-
Equipment Weight (kg, ±%3)	Determined by the Sketch Study	Determined by the Sketch Study	Determined by the Sketch Study

Dimensions are final dimensions. The dimensions and weights may vary depending on the crane and vehicle that will be used.

2. Technical Features

OKG	
Maximum Lifting Capacity	11-15-20 Tons/Meter
Pump Capacity	40-60 lt/min.
Maximum Operating Pressure	180 Bar
Maximum Turning Angle	360°
BOM Operating Angle	+75°/-15°

3. Hydraulic Features

Hydraulic Features		
Pump	Pump Types	Gear Pump
	Operating Pressure	180 bar
	Pump Flow Rate	OKG
		40-60 lt/min
* Pump values may differ depending on motor output speed. Motor output speed Max. 1000rpm		
Oil Tank	Capacity	OKG 80 – 120 lt
	Suction Filter	125 µc
	Return Filter	25 µc

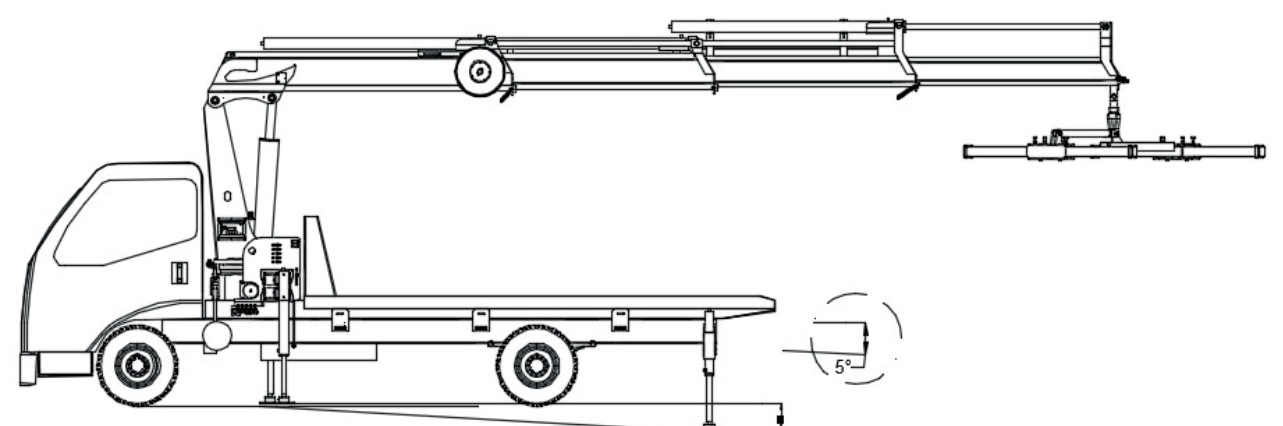

4. Optional Features

Hydraulic Control System	Manual	Recorder	
Inner Cabin Control	 Touch-screen Control  Button Control	Mud Guards	
Beacon Light		Warning System	
Camera		Bicycle Stand	
CANBUS - ECU			

Please contact DRAKCI MAKİNA for optional requests.

- Following the analysis of each designed equipment via the programs, mass production of them is carried out after testing for at least 6 months in the field test.
- CKD-SKD and Disassembled production can be performed. Production can be made in line with business models depending on customer and market needs.
- Through the installation of a closed-circuit camera system in the driver's cabin, the communication of the driver with the operators is increased and work safety is ensured. Ease of use is offered via an optional touch screen.
- 1-year product warranty and 10-year spare parts supply warranty are provided

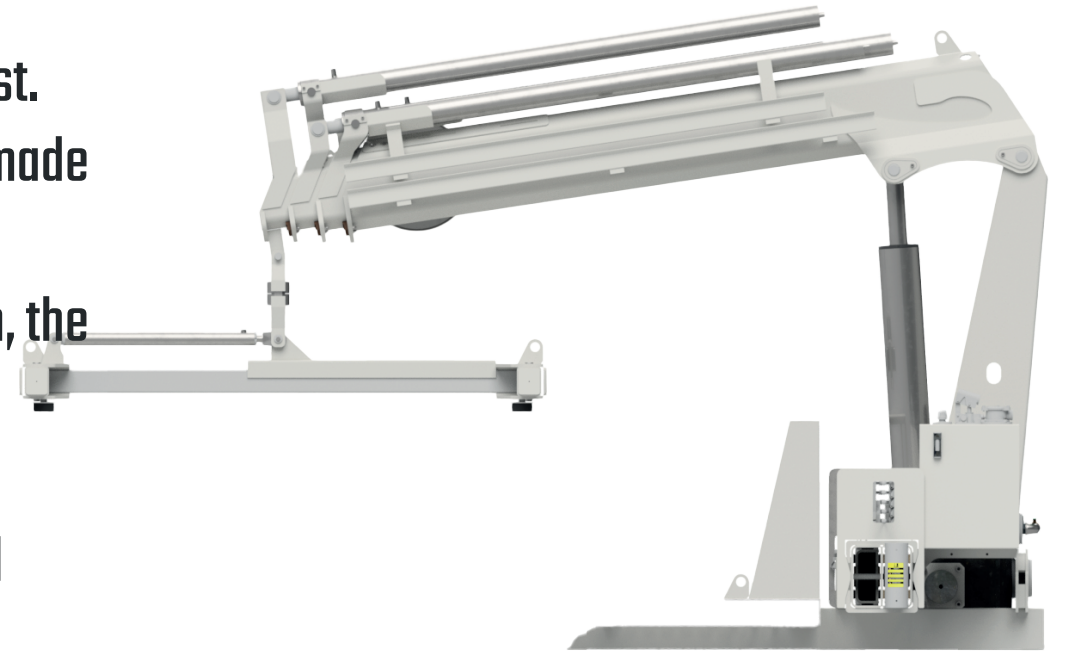

orakcimakina.com

Click to 
Contact Us!